

## MODULE 3

# Introduction to Internal Combustion Engines

**Asst. Prof. Vishnu Sankar**

Department of Mechanical Engineering  
Rajagiri School of Engineering & Technology (RSET)

# HEAT ENGINE

Any engine that converts **thermal energy** to **mechanical work output**.

Ex: steam engine, steam power plant, jet engine, gas turbine power plant, diesel engine, and gasoline (petrol) engine etc.

On the basis of **how thermal energy is being delivered to working fluid** of the heat engine, Heat engine can be classified as

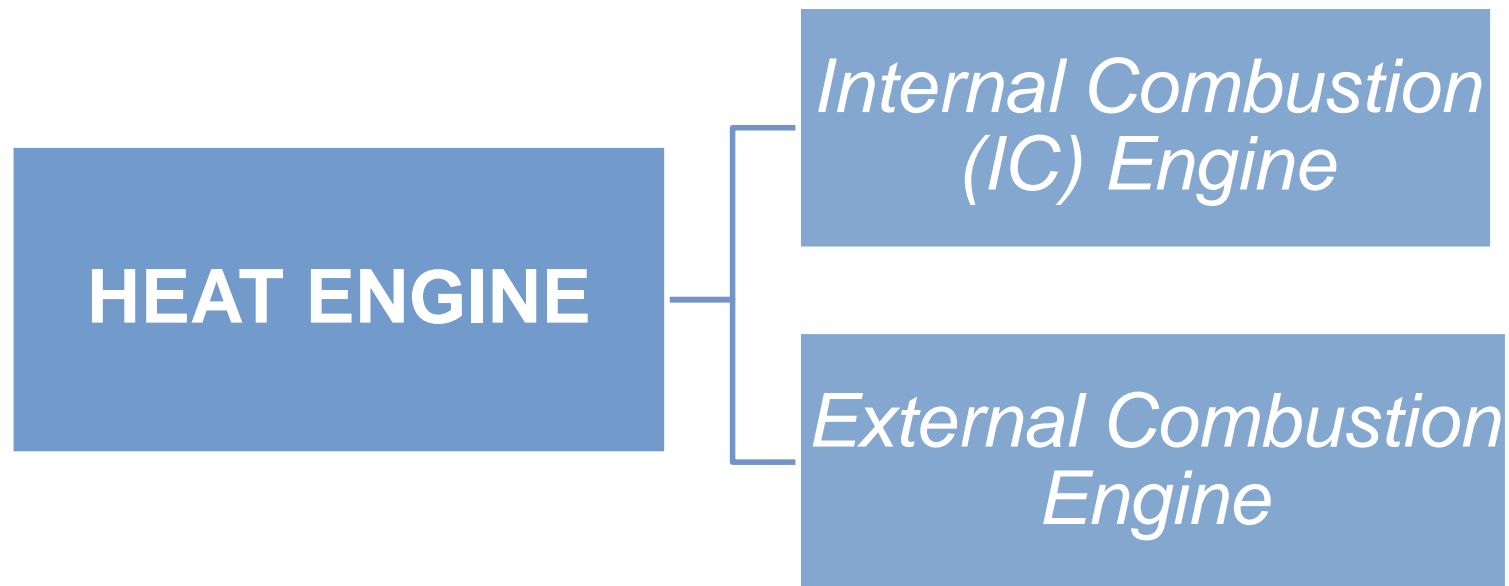

## Internal combustion engine:

Combustion takes place **within** the working fluid of the engine,

- *Thus fluid gets contaminated with combustion products.*
- Petrol engine is an example of internal combustion engine, where the working fluid is a mixture of air and fuel .

## External combustion engine

Working fluid gets energy **from outside** through some heat exchanger (Boiler)

- Thus the working fluid does not come in contact with combustion products.
- Steam engine is an example of external combustion engine, where the working fluid is steam.

# INTERNAL COMBUSTION ENGINES

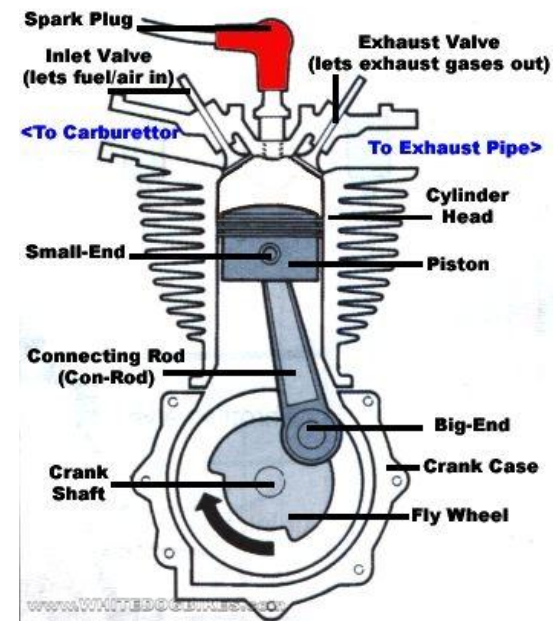
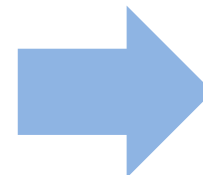
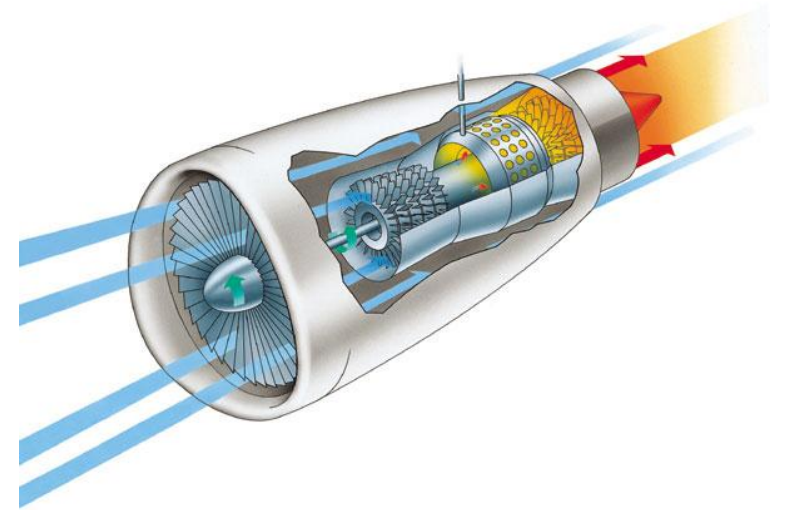
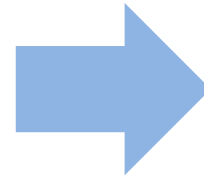



# EXTERNAL COMBUSTION ENGINES

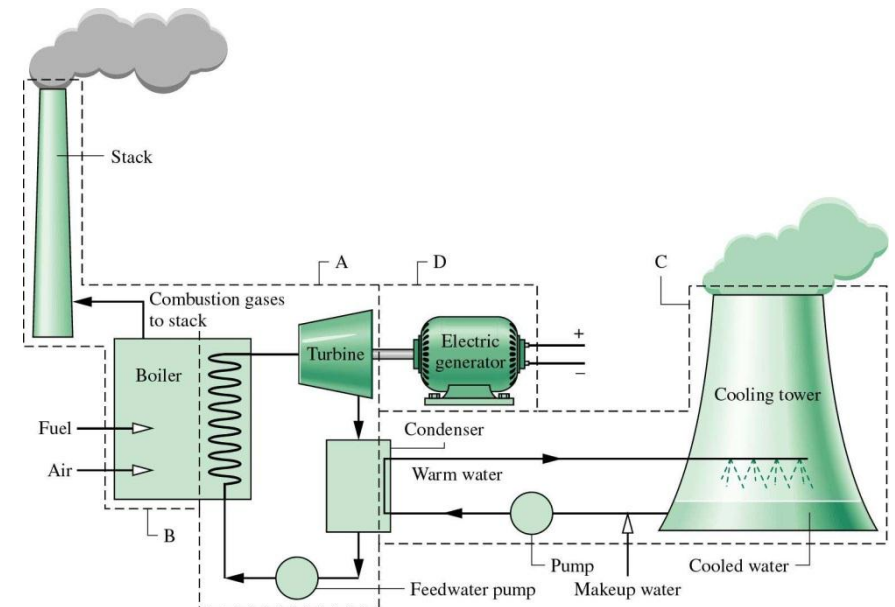
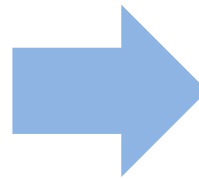
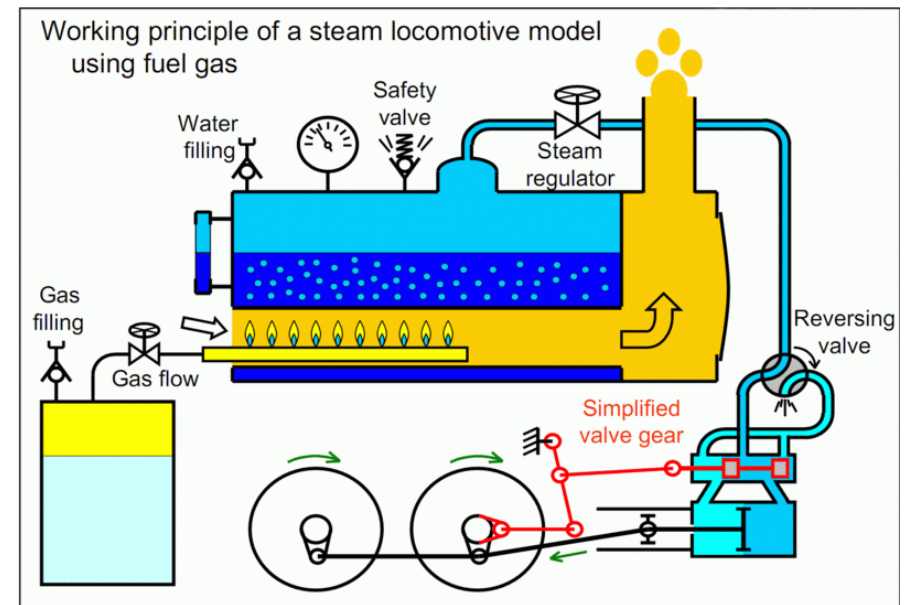
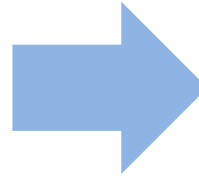

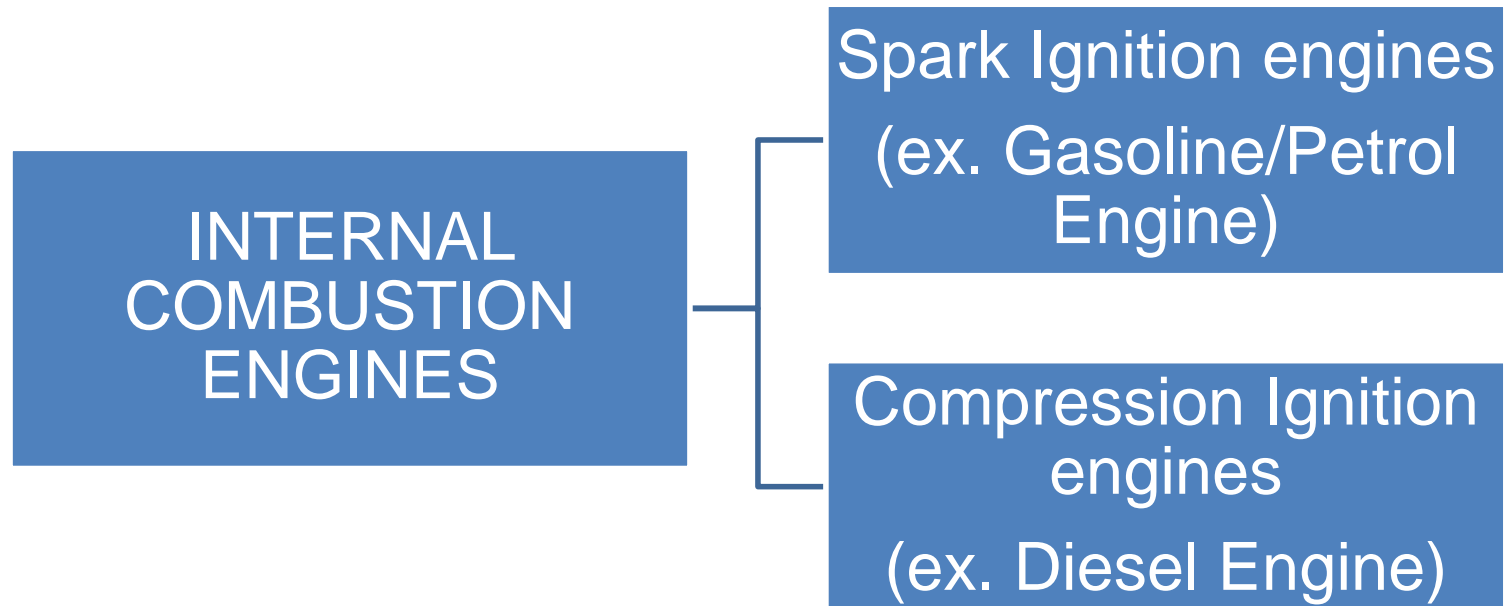

## Spark ignition engine (SI engine)

An engine in which the combustion process in each cycle is started by use of an **external spark**.

## Compression ignition engine (CI engine)

An engine in which the combustion process starts when the air-fuel mixture **self ignites** due to high temperature in the combustion chamber caused by high compression.

*[Spark ignition and Compression Ignition engine operate on either a **four stroke cycle** or a **two stroke cycle**]*



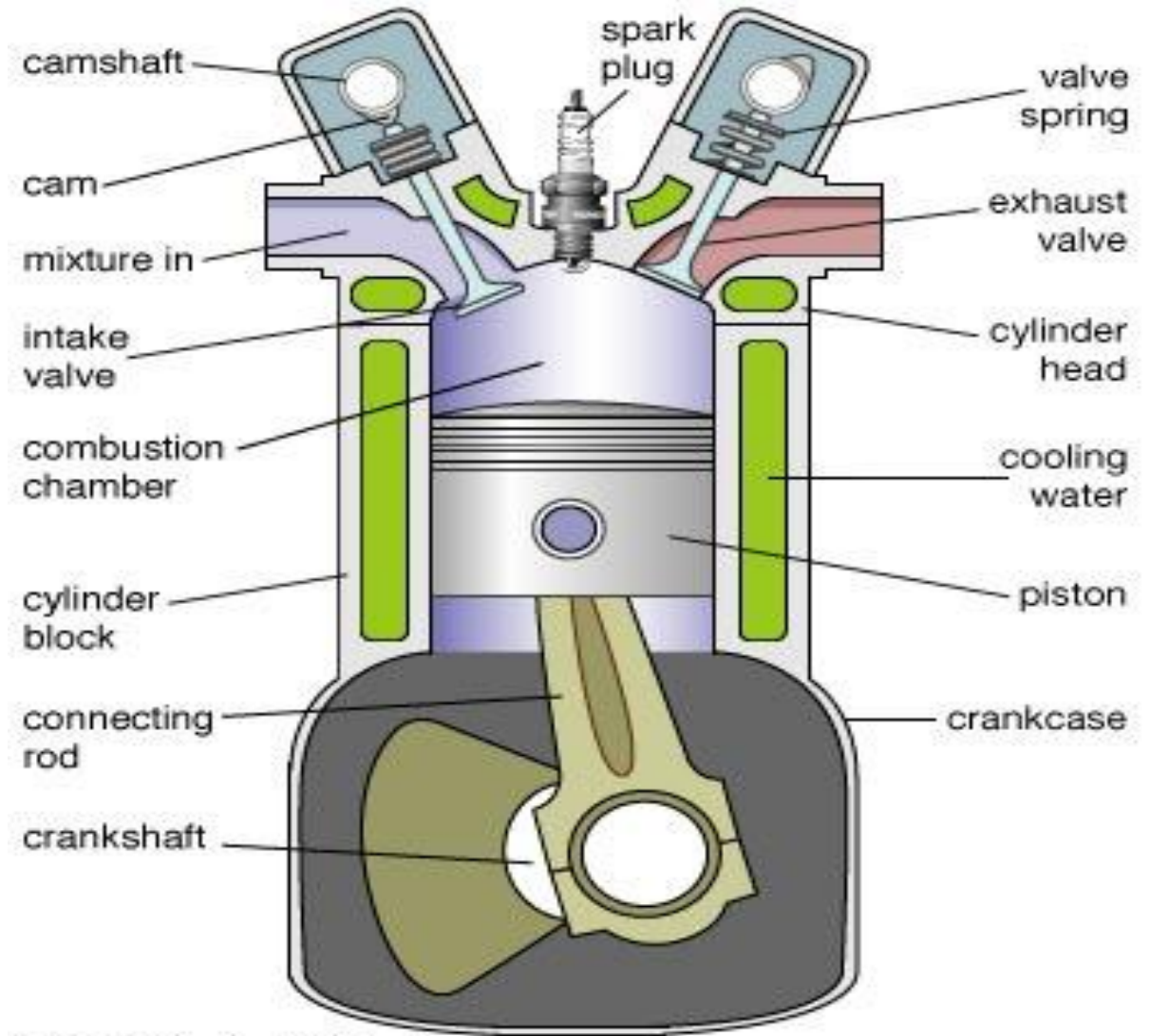
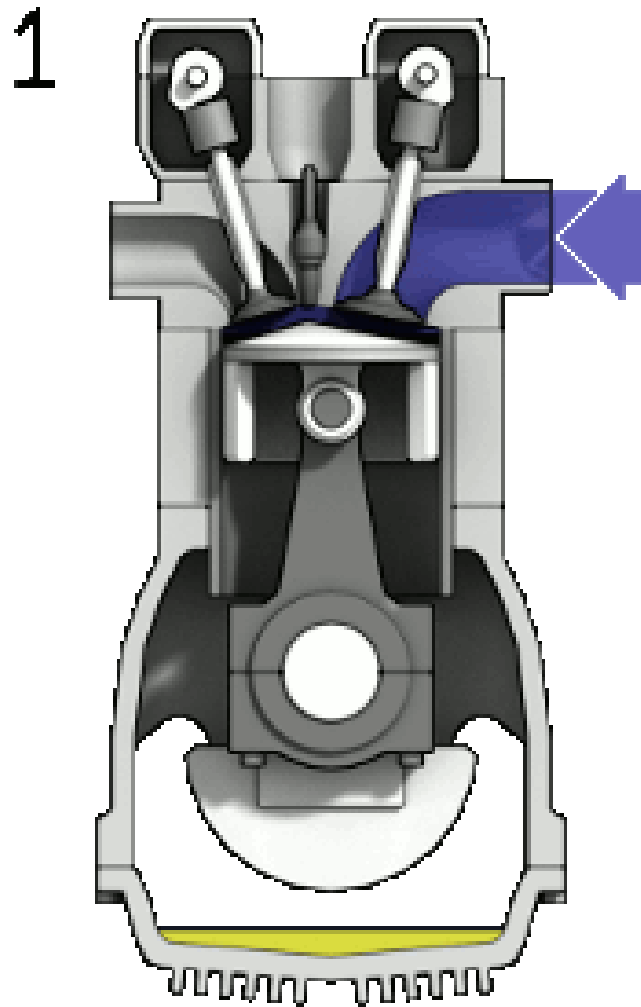

© 2006 Merriam-Webster, Inc.

## IC Engine components

## Engine (Exploded View)

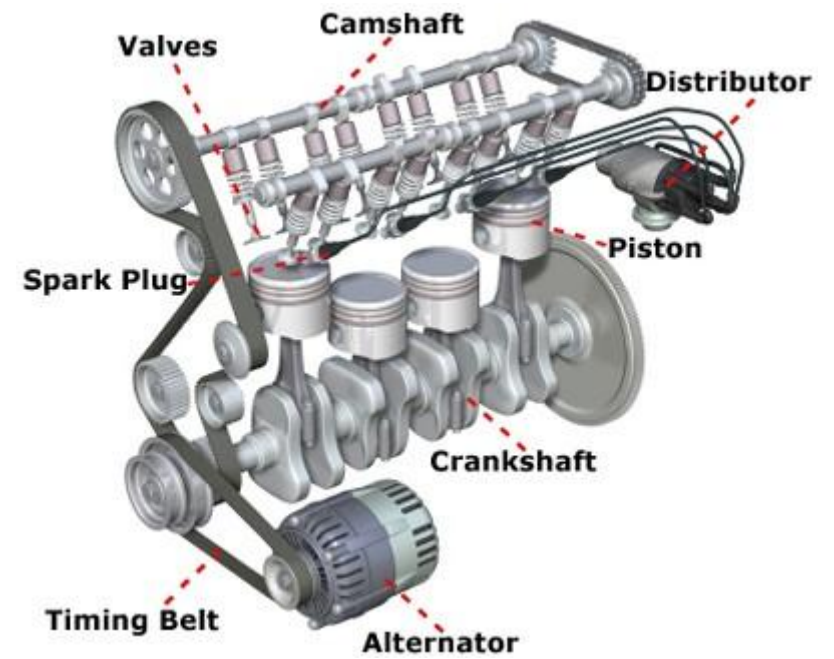
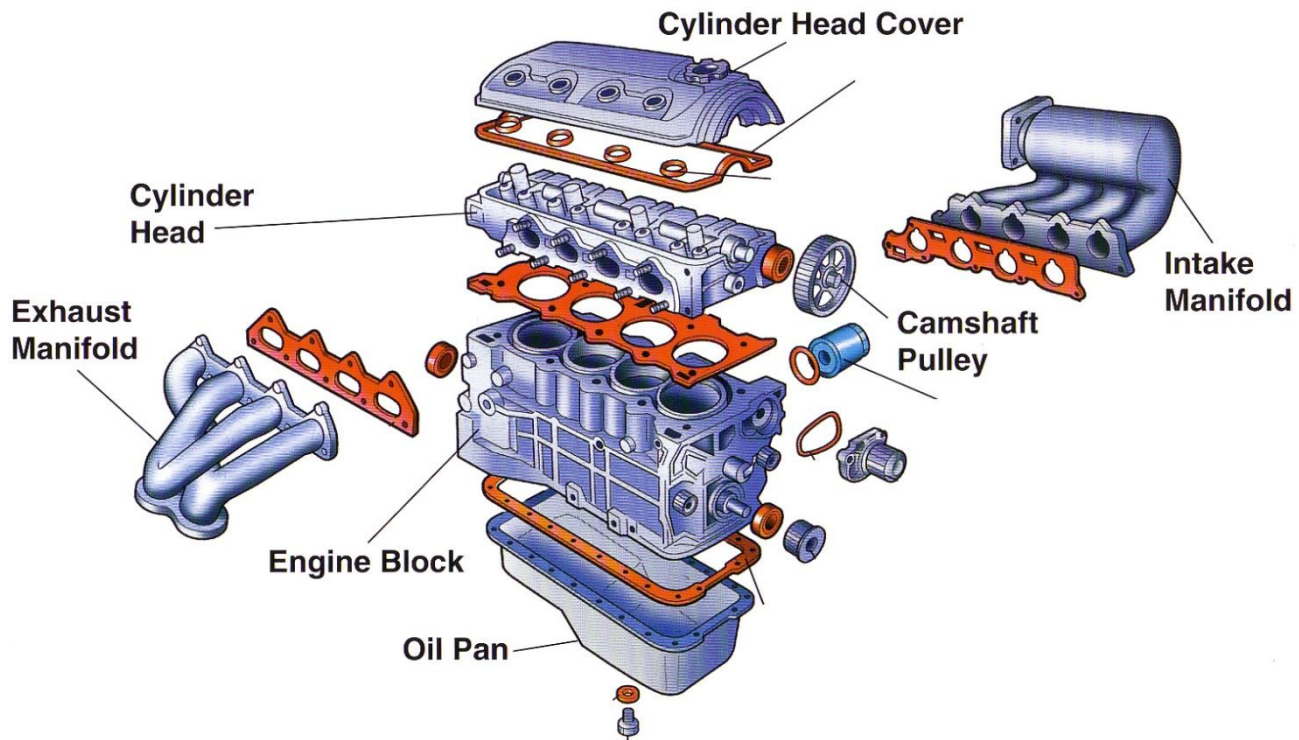

# I C Engine Components

- **Block** : Body of the engine containing cylinders, made of cast iron or aluminium.
- **Cylinder** : The circular cylinders in the engine block in which the pistons reciprocate back and forth.
- **Head** : The piece which closes the end of the cylinders, usually containing part of the clearance volume of the combustion chamber.
- **Combustion chamber**: The end of the cylinder between the head and the piston face where combustion occurs.
  - The size of combustion chamber continuously changes from minimum volume when the piston is at TDC to a maximum volume when the piston at BDC.

- **Crankshaft** : Rotating shaft through which engine work output is supplied to external systems.
  - The crankshaft is connected to the engine block with the main bearings.
  - It is rotated by the reciprocating pistons through the connecting rods connected to the crankshaft, offset from the axis of rotation. This offset is sometimes called crank throw or crank radius.
- **Connecting rod** : Rod connecting the piston with the rotating crankshaft, usually made of steel or alloy forging in most engines but may be aluminum in some small engines.
- **Piston rings**: Metal rings that fit into circumferential grooves around the piston and form a sliding surface against the cylinder walls.

- **Camshaft** : Rotating shaft used to push open valves at the proper time in the engine cycle, either directly or through mechanical or hydraulic linkage (push rods, rocker arms, tappets) .
- **Crankcase** : Part of the engine block surrounding the crankshaft.
  - In many engines the oil pan makes up part of the crankcase housing.
- **Exhaust manifold** : Piping system which carries exhaust gases away from the engine cylinders, usually made of cast iron .

- **Intake manifold** :Piping system which delivers incoming air to the cylinders, usually made of cast metal, plastic, or composite material.
  - In most SI engines, fuel is added to the air in the intake manifold system either by fuel injectors or with a carburetor.
  - The individual pipe to a single cylinder is called runner.
- **Spark plug** : Electrical device used to initiate combustion in an SI engine by creating high voltage discharge across an electrode gap.



- **Flywheel** : Rotating mass with a large moment of inertia connected to the crank shaft of the engine.
  - The purpose of the flywheel is to store energy and furnish large angular momentum that keeps the engine rotating between power strokes and smooths out engine operation.
- **Fuel injector** : A pressurized nozzle that sprays fuel into the incoming air (SI engines )or into the cylinder (CI engines).
- **Fuel pump** : Electrically or mechanically driven pump to supply fuel from the fuel tank (reservoir) to the engine.

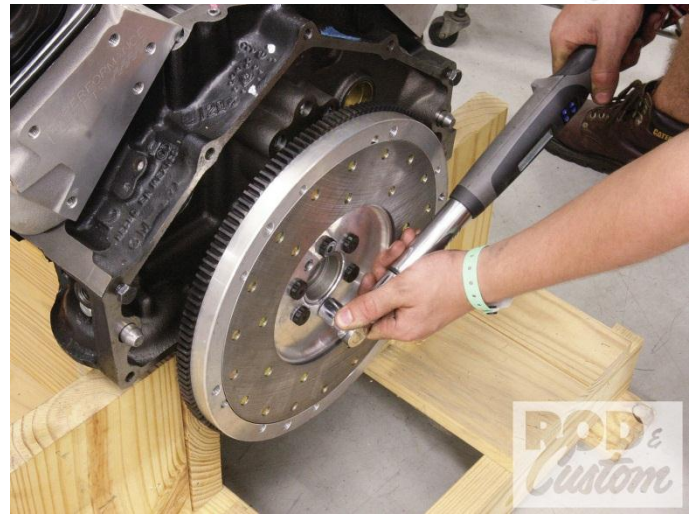
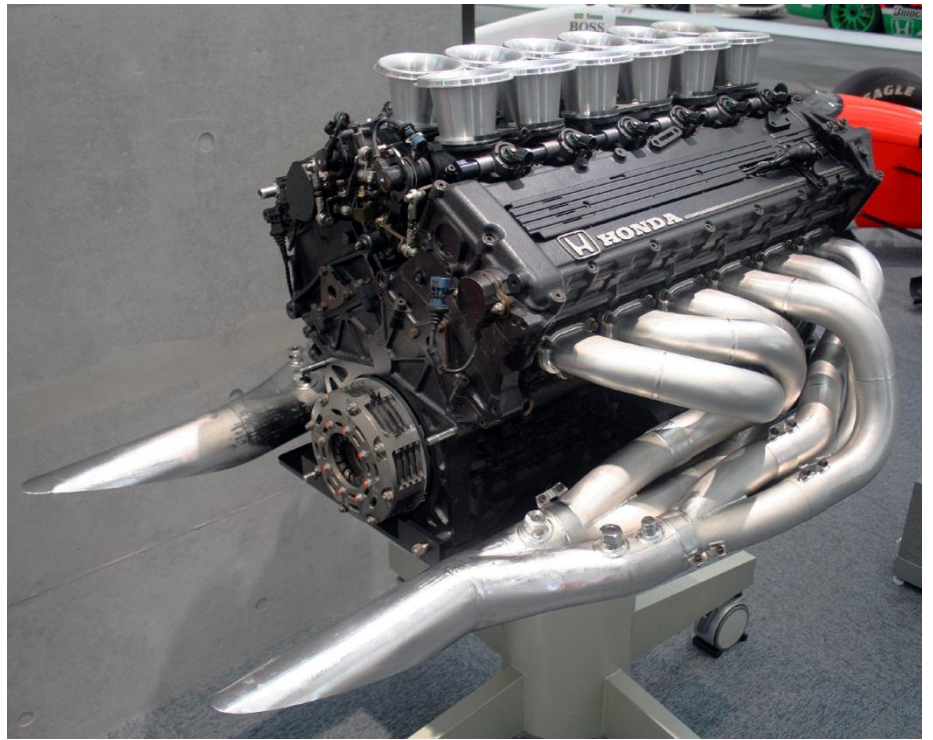

# IC Engines

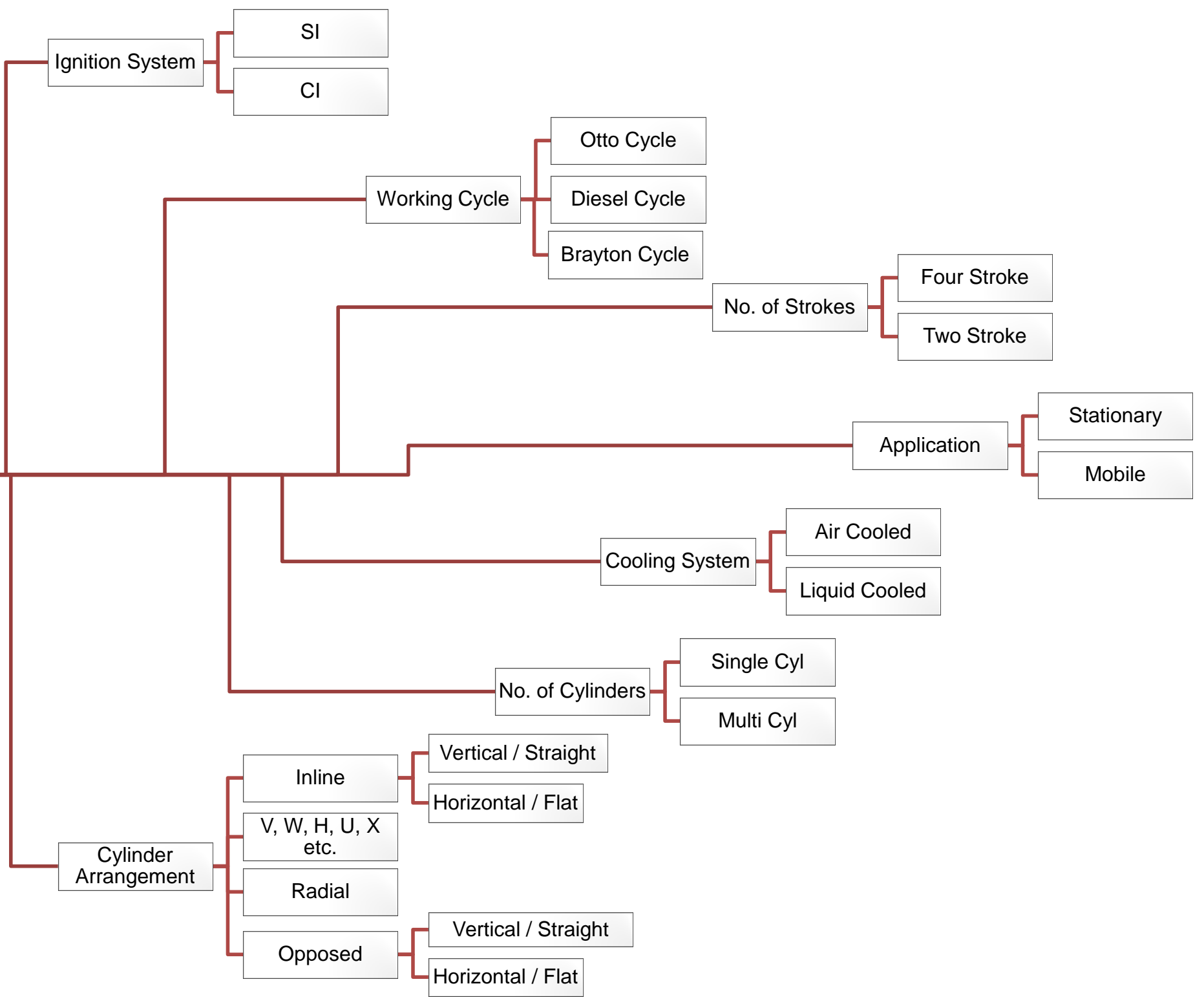

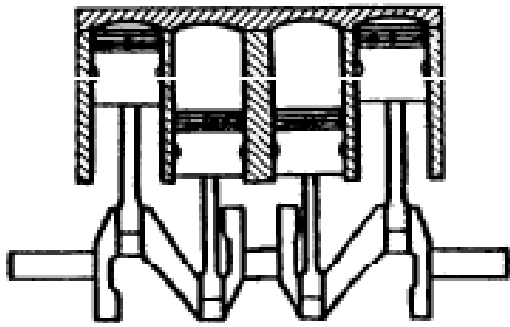

(A) IN-LINE

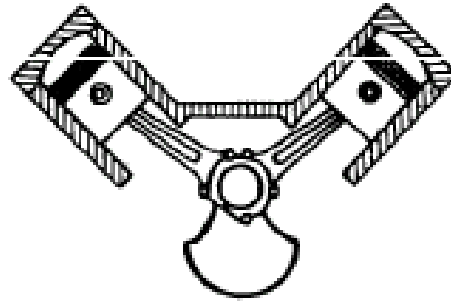

(B) V-TYPE

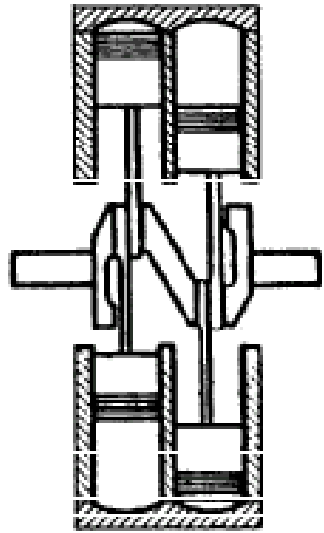

(C) OPPOSED  
(HORIZONTAL OR VERTICAL)

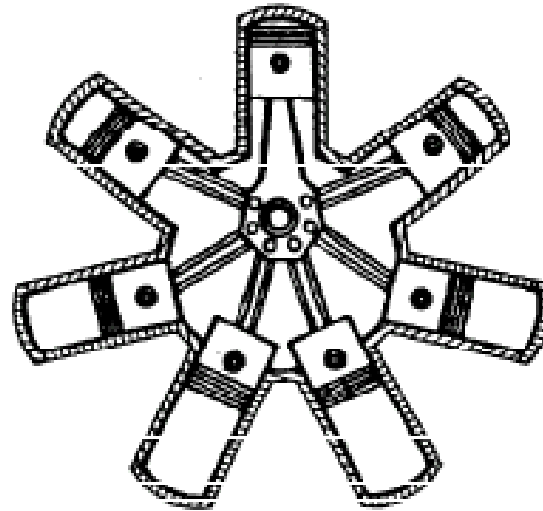

(D) RADIAL

Figure 2-10.—Typical cylinder arrangements

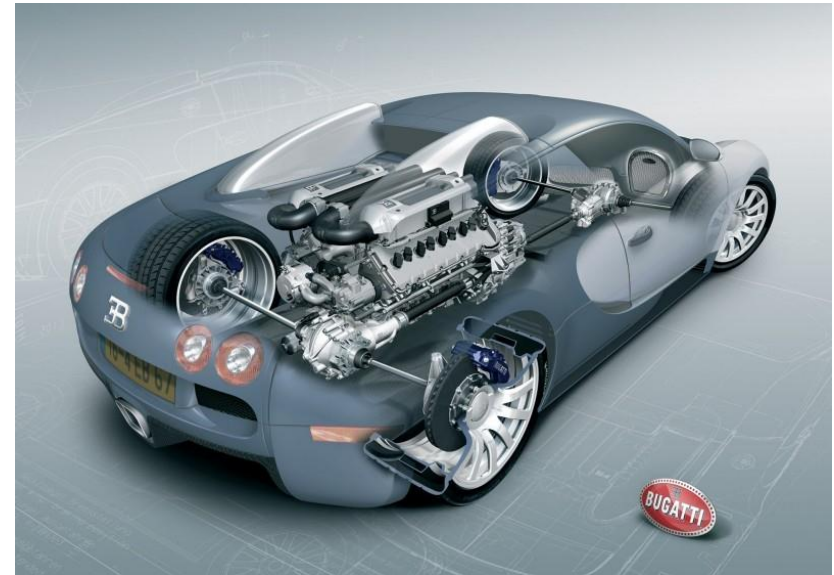

Bugatti W 16

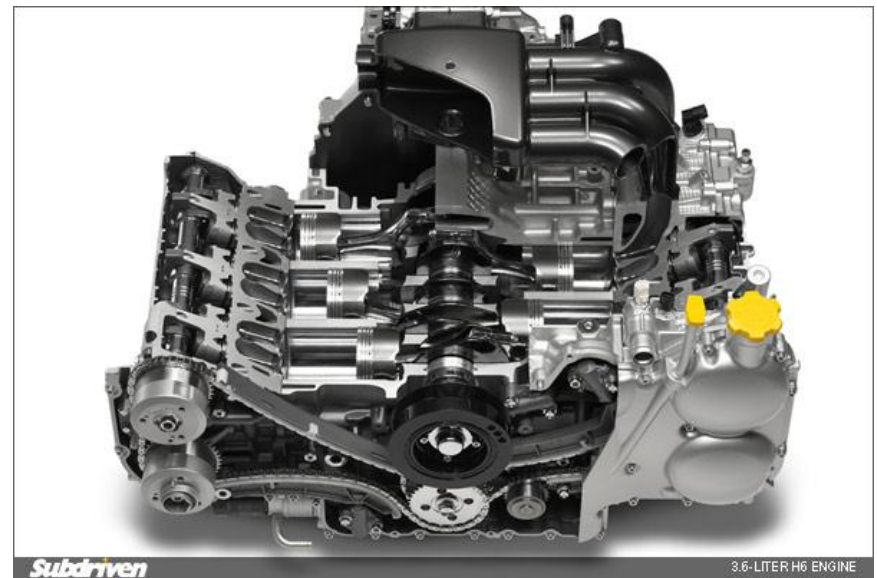

Subaru H6

- Four stroke cycle : It has four piston strokes over two revolutions for each cycle.
- Two stroke cycle : It has two piston strokes over one revolution for each cycle.
- We will be dealing with Spark Ignition engine and Compression Ignition engine operating on a four stroke cycle.



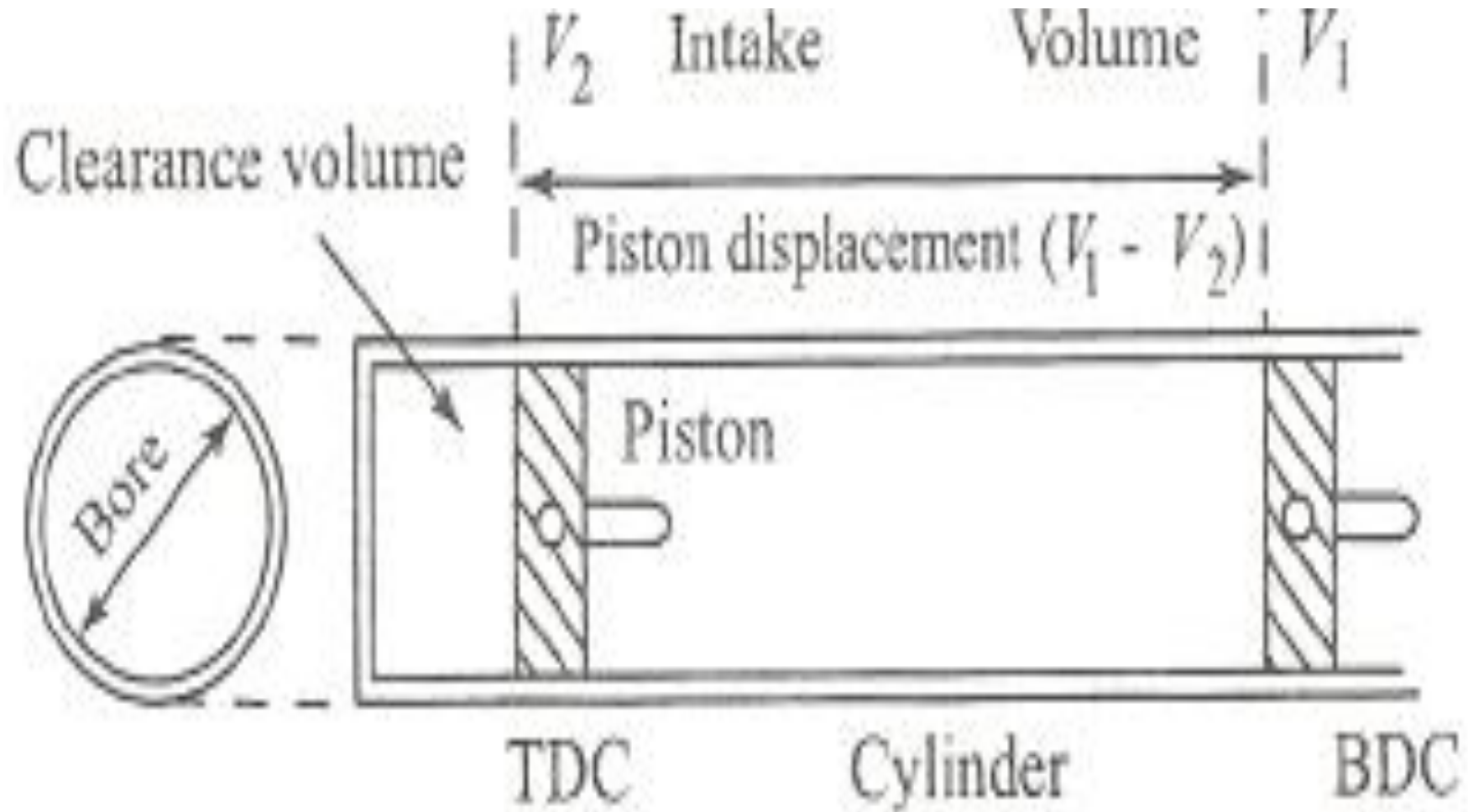

Figure3 : Engine Terminology



# Engine Terminology :

- **Figure 3**, shows the pressure volume diagram of ideal engine cycle along with engine terminology as follows:
- **Top Dead Center (TDC):** Position of the piston when it stops at the furthest point away from the crankshaft.
  - Top because this position is at the top of the engines (not always), and dead because the piston stops at this point. Because in some engines **TDC** is not at the top of the engines(e.g: horizontally opposed engines, radial engines,etc,.) Some sources call this position **Head End Dead Center (HEDC)**.
    - Some source call this point **TOP Center (TC)**.
    - When the piston is at TDC, the volume in the cylinder is a minimum called the clearance volume.

**Bottom Dead Center (BDC):** Position of the piston when it stops at the point closest to the crankshaft.

- Some sources call this **Crank End Dead Center (CEDC)** because it is not always at the bottom of the engine. Some source call this point **Bottom Center (BC)**.

• **Stroke** : Distance traveled by the piston from one extreme position to the other : TDC to BDC or BDC to TDC.

• **Bore** : It is defined as cylinder diameter or piston face diameter; piston face diameter is same as cylinder diameter (minus small clearance).

• **Swept volume/Displacement volume** : Volume displaced by the piston as it travels through one stroke.

- Swept volume is defined as stroke times bore.
- Displacement can be given for one cylinder or entire engine (one cylinder times number of cylinders).

- **Clearance volume** : It is the minimum volume of the cylinder available for the charge (air or air fuel mixture) when the piston reaches at its outermost point (top dead center or outer dead center) during compression stroke of the cycle.
  - Minimum volume of combustion chamber with piston at TDC.
- **Compression ratio** : The ratio of total volume to clearance volume of the cylinder is the compression ratio of the engine.
  - Typically compression ratio for SI engines varies from 8 to 12 and for CI engines it varies from 12 to 24

# SI Engine Ideal Otto Cycle

- We will be dealing with four stroke SI engine, the following figure shows the PV diagram of Ideal Otto cycle.

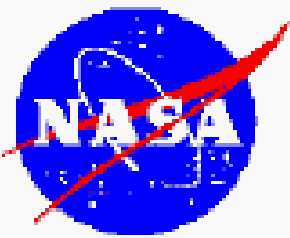

# Internal Combustion Engine

## Ideal Otto Cycle

Glenn  
Research  
Center

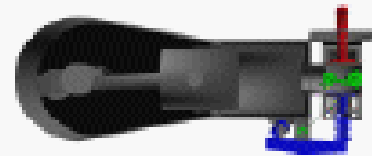

Stage 5 – End Power Stroke  
Begin Heat Rejection

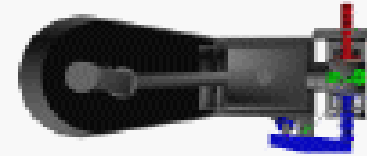

Stage 4 – End Combustion  
Begin Power Stroke

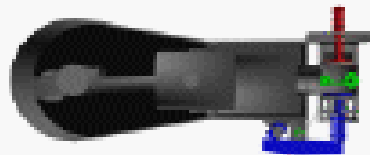

Stage 6 – Begin Exhaust Stroke  
End Heat Rejection

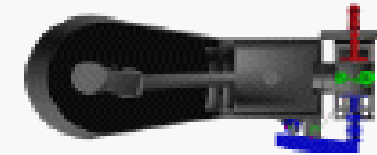
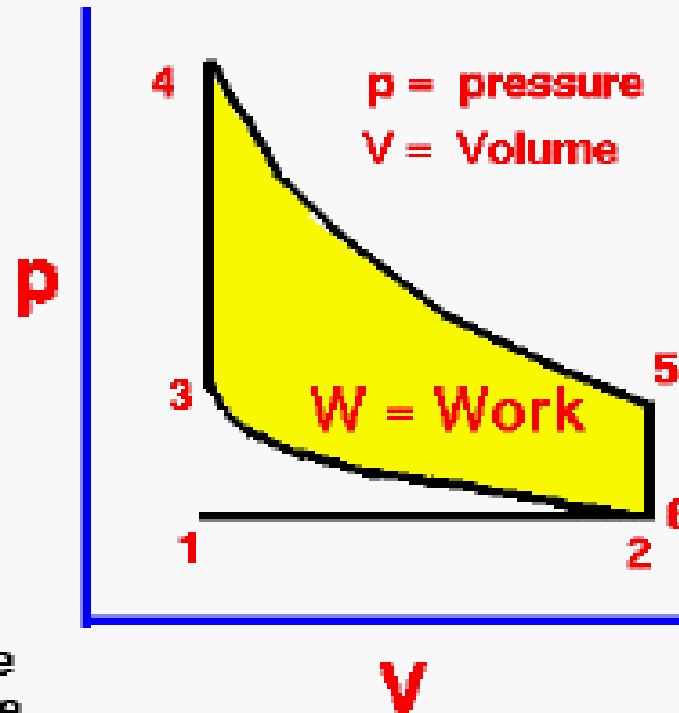

Stage 3 – Begin Combustion  
End Compression Stroke

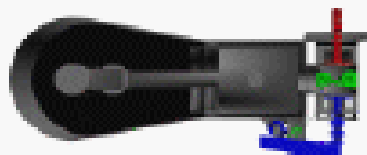

Stage 1 – Begin Intake Stroke  
End Exhaust Stroke

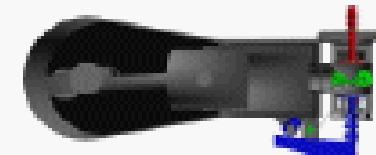

Stage 2 – End Intake Stroke  
Begin Compression Stroke

Work available from the cycle equals enclosed area of p-V diagram.

Power equals work times cycle per second.

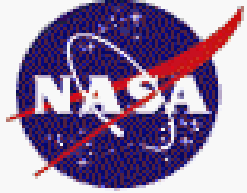

# Engine Stages

Asst. Prof. Abhinav Sankar, DME, RSET

Glenn  
Research  
Center

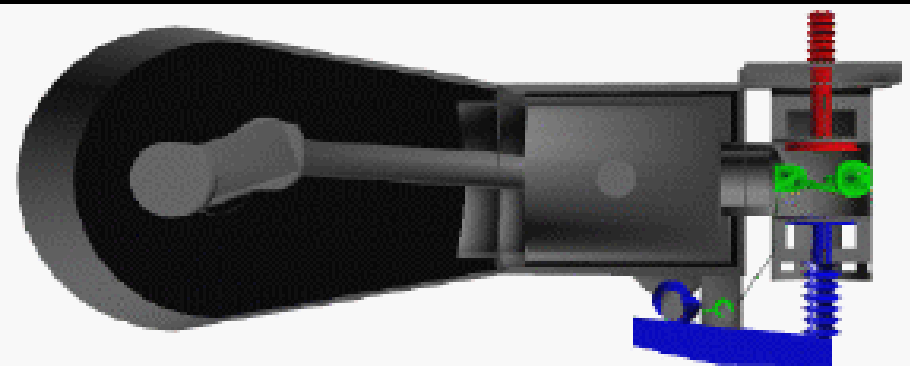

**Stage 1 – Begin Intake Stroke**

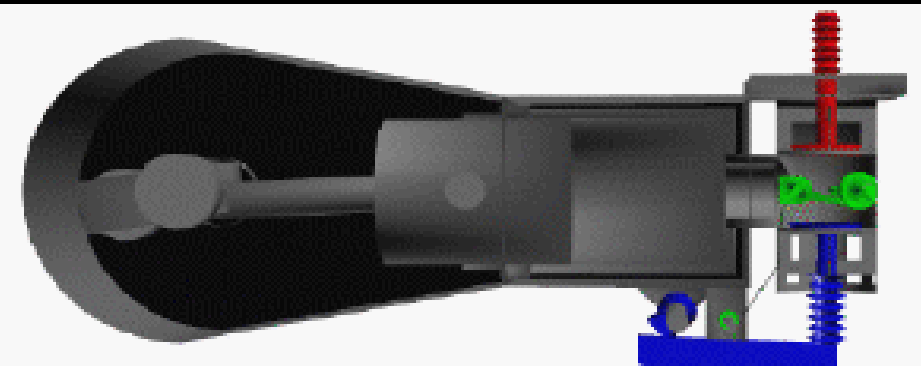

**Stage 6 – Begin Exhaust Stroke**



**Stage 2 – Begin Compression Stroke**



**Stage 5 – Begin Heat Rejection**

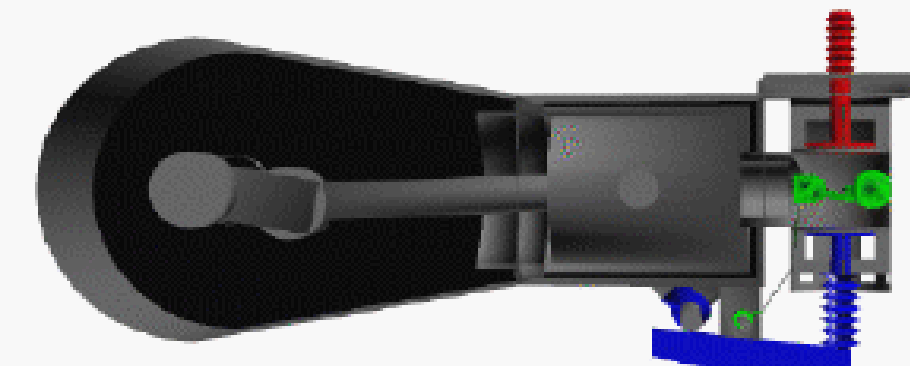

**Stage 3 – Begin Combustion**

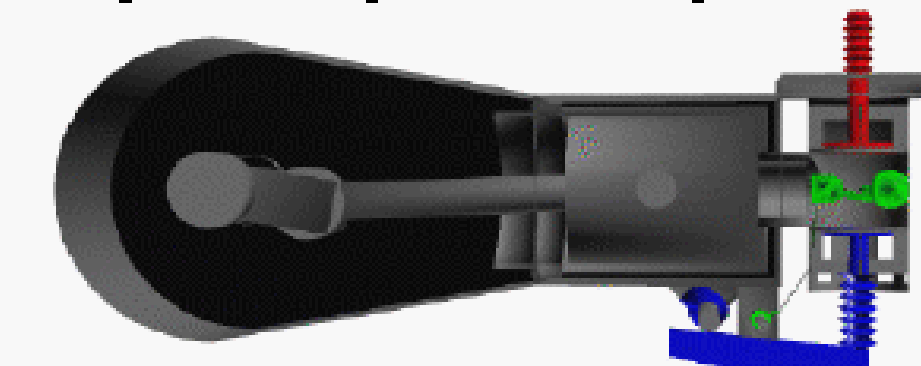

**Stage 4 – Begin Power Stroke**



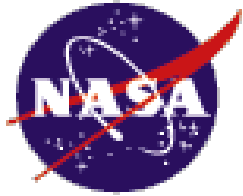

# Ideal Otto Cycle

*p-V diagram*

Glenn  
Research  
Center

V = Volume  
p = pressure

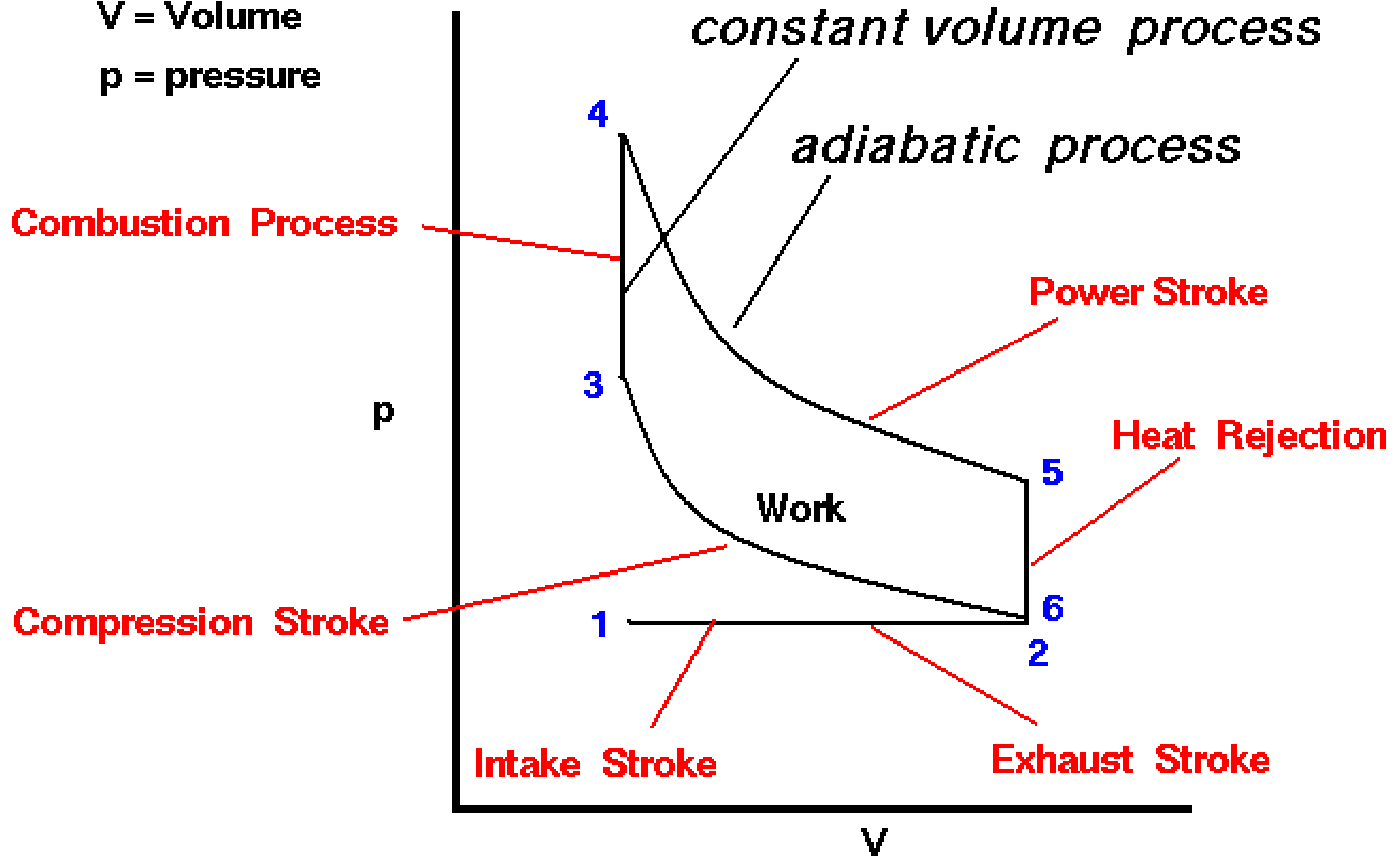

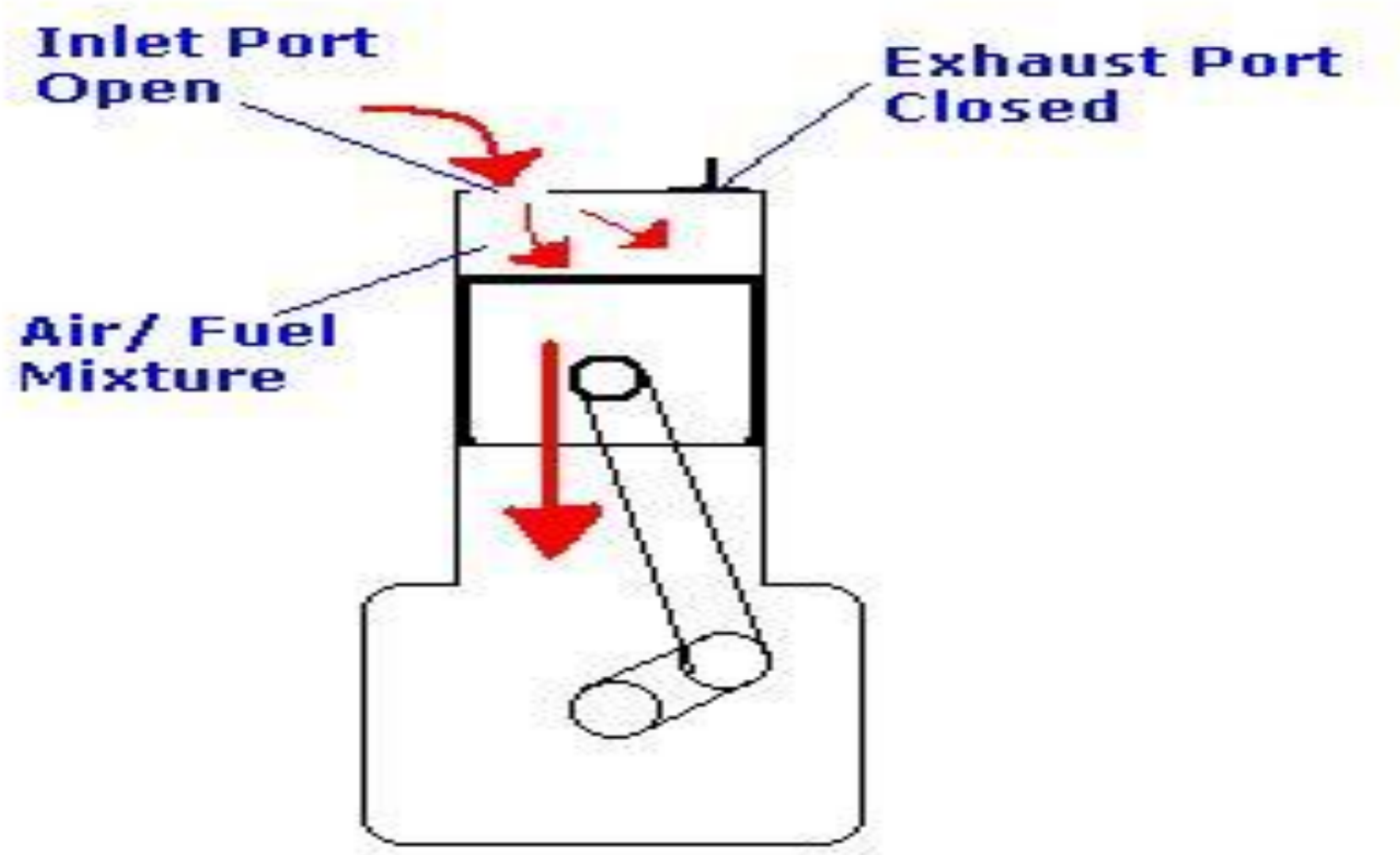

Figure4: Suction stroke

# Four strokes of SI Engine Cycle :

- **Suction/Intake stroke:** Intake of air fuel mixture in cylinder through intake manifold.
  - The piston travel from TDC to BDC with the intake valve open and exhaust valve closed.
  - This creates an increasing volume in the combustion chamber, which in turns creates a vacuum.
  - The resulting pressure differential through the intake system from atmospheric pressure on the outside to the vacuum on the inside causes air to be pushed into the cylinder.
  - As the air passes through the intake system fuel is added to it in the desired amount by means of fuel injectors or a carburettor.

**Air/Fuel  
Mixture  
Compressed**

**Both Ports  
Closed**

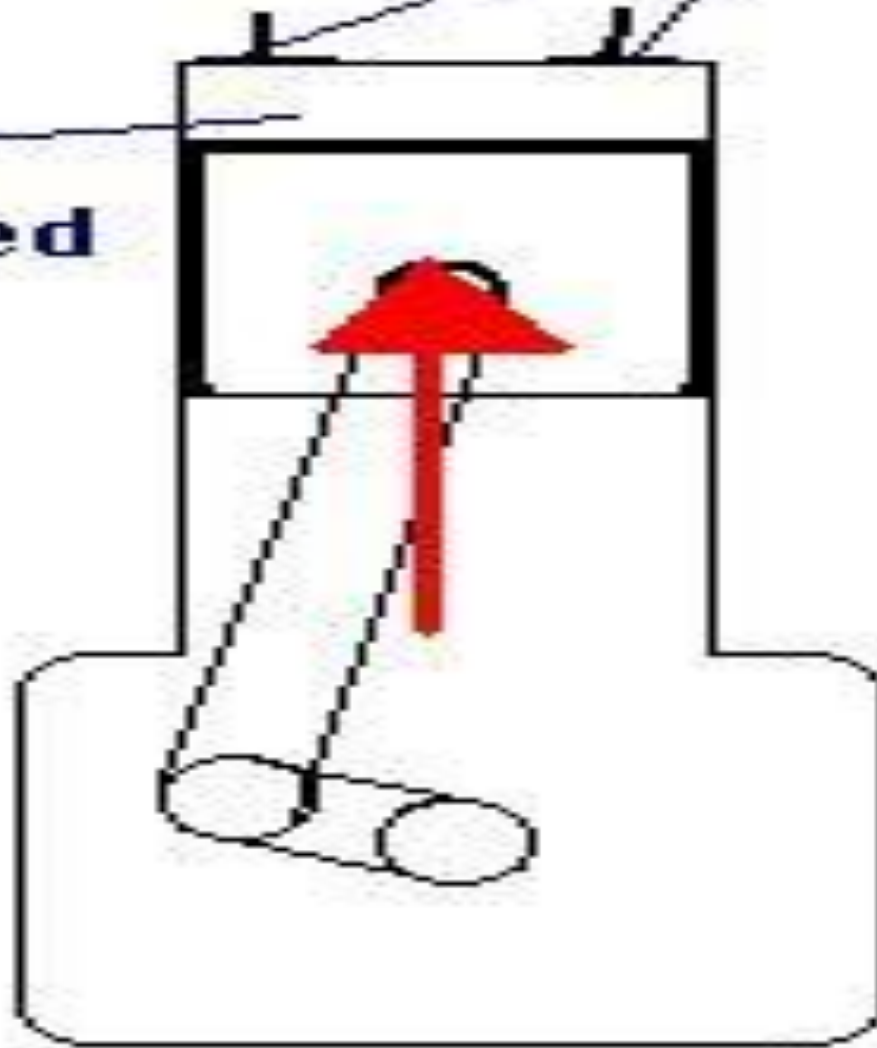

Figure5: Compression Stroke

- **Compression stroke:** When the piston reaches BDC, the intake valve closes and the piston travels back to TDC with all valves closed.
  - This compresses air fuel mixture, raising both the pressure and temperature in the cylinder.
  - Near the end of the compression stroke the spark plug is fired and the combustion is initiated.

- **Combustion** of the air-fuel mixture occurs in a very short but finite length of time with the piston near TDC (i.e., nearly constant volume combustion).
  - It starts near the end of the compression stroke slightly before TDC and lasts into the power stroke slightly after TDC.
  - Combustion changes the composition of the gas mixture to that of exhaust products and increases the temperature in the cylinder to a high value.
  - This in turn increases the pressure in the cylinder to a high value.



**Air/Fuel  
Mixture  
Burnt**

**Both Ports  
Closed**

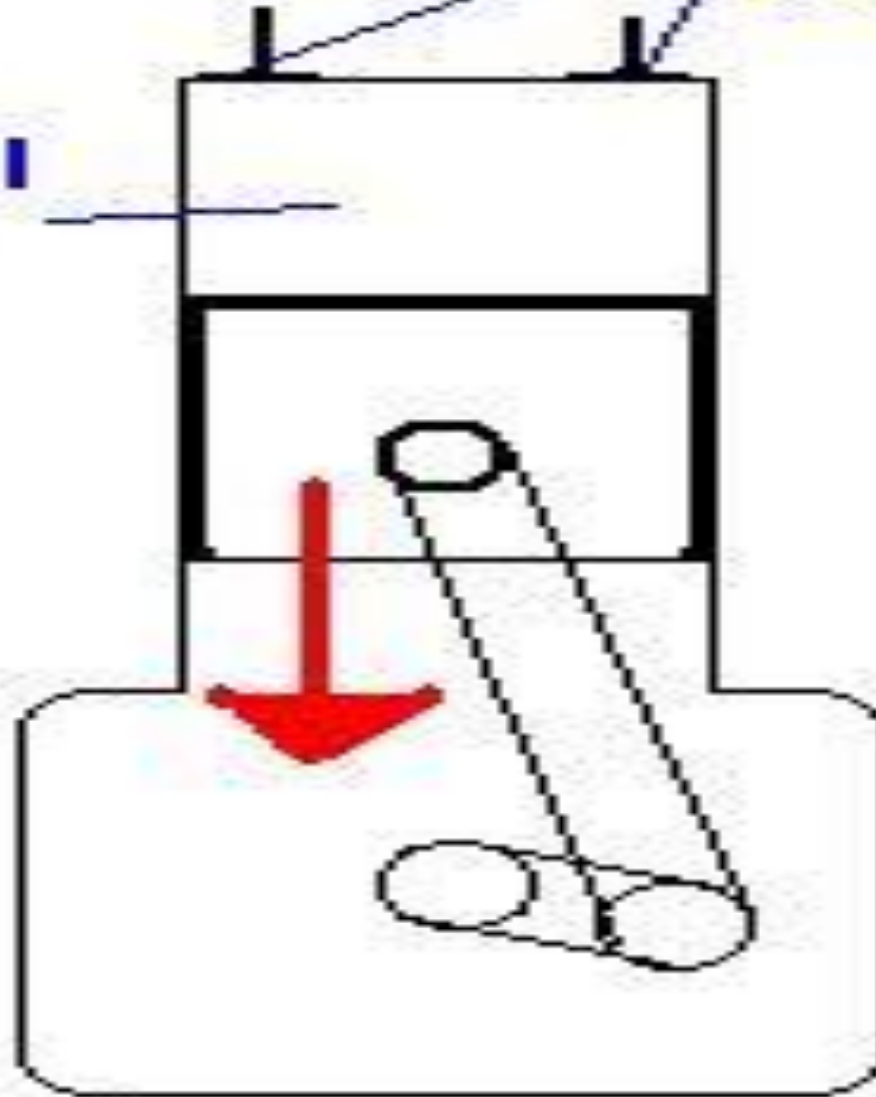

Figure6: Combustion followed by Expansion stroke.

- **Expansion stroke/Power stroke** : With all valves closed the high pressure created by the combustion process pushes the piston away from the TDC.
  - This is the stroke which produces work output of the engine cycle.
  - As the piston travels from TDC to BDC, cylinder volume is increased, causing pressure and temperature to drop.

**Exhaust Blowdown** : Late in the power stroke, the exhaust valve is opened and exhaust blowdown occurs.

- Pressure and temperature in the cylinder are still high relative to the surroundings at this point, and a pressure differential is created through the exhaust system which is open to atmospheric pressure.
- This pressure differential causes much of the hot exhaust gas to be pushed out of the cylinder and through the exhaust system when the piston is near BDC.
- This exhaust gas carries away a high amount of enthalpy, which lowers the cycle thermal efficiency.
- Opening the exhaust valve before BDC reduces the work obtained but is required because of the finite time needed for exhaust blowdown.

**Inlet Port  
Closed**

**Exhaust Port  
Open**

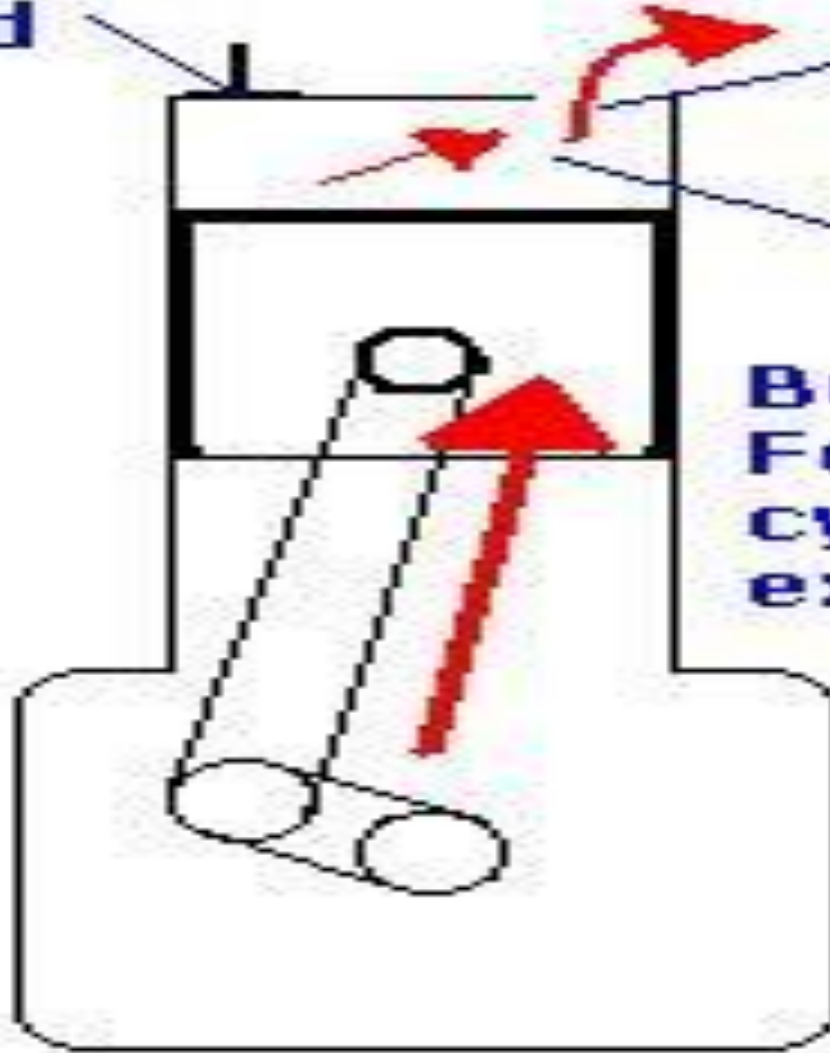

**Burnt Gases are  
Forced out of the  
cylinder via the  
exhaust port**

Figure7: Exhaust blowdown followed by Exhaust stroke

- **Exhaust stroke:** By the time piston reaches BDC, exhaust blowdown is complete, but the cylinder is still full of exhaust gases at approximately atmospheric pressure.
  - With the exhaust valve remaining open, the piston travels from BDC to TDC in the exhaust stroke.
  - This pushes most of the remaining exhaust gases out of the cylinder into the exhaust system at about atmospheric pressure, leaving only that trapped in the clearance volume when the piston reaches TDC.

- Near the end of the exhaust stroke before TDC, the intake valve starts to open, so that it is fully open by TDC when the new intake stroke starts the next cycle.
- Near TDC the exhaust valve starts to close and finally is fully closed sometime after TDC.
- This period when both the intake valve and exhaust valve are open is called **valve overlap**, it can be clearly seen in valve timing chart given below.

## VALVE TIMING CHART

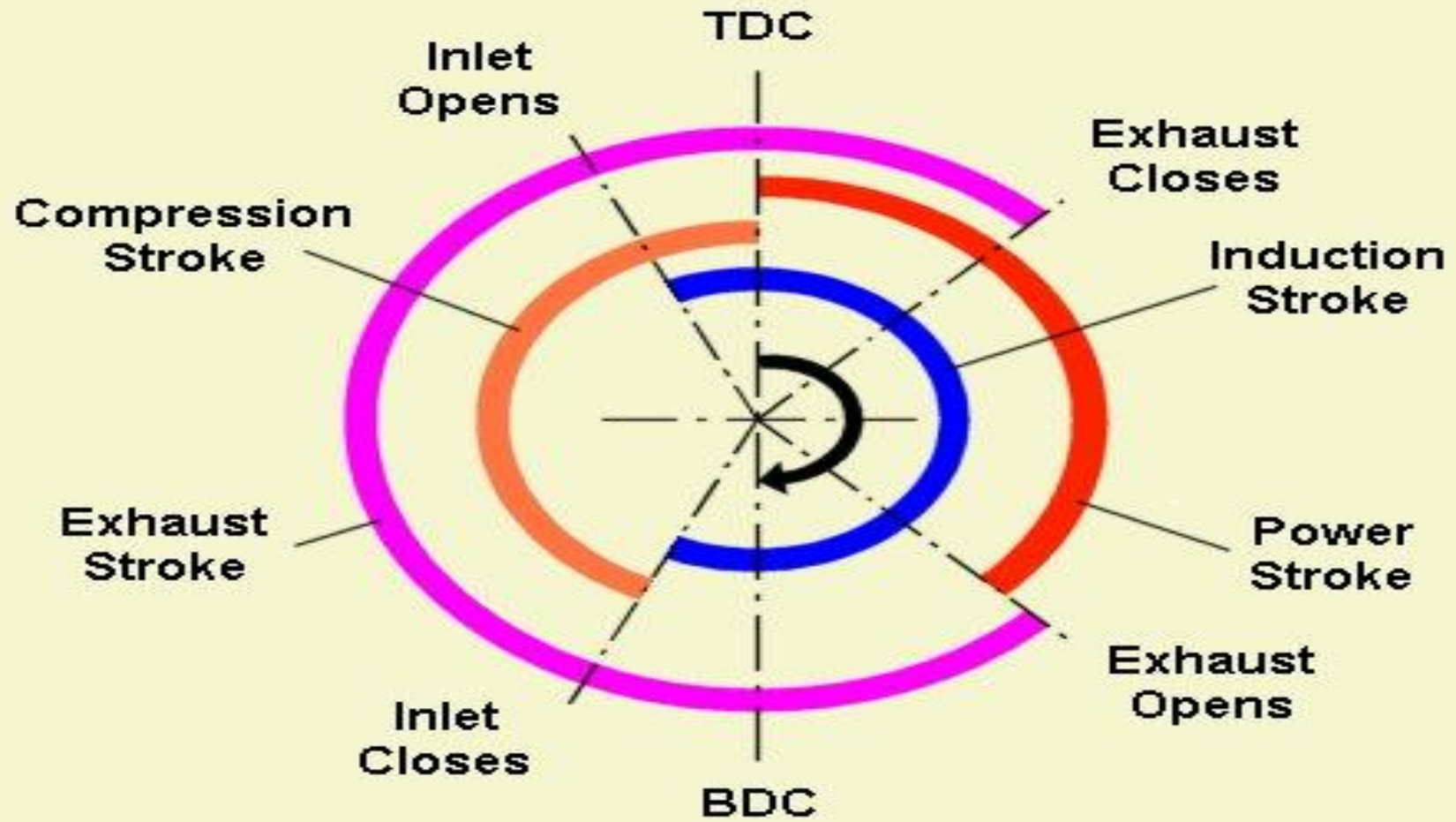

# Compression Ignition Engine :

- We will deal with Compression Ignition engine.
- The ideal diesel cycle PV diagram is shown in following figure 8.



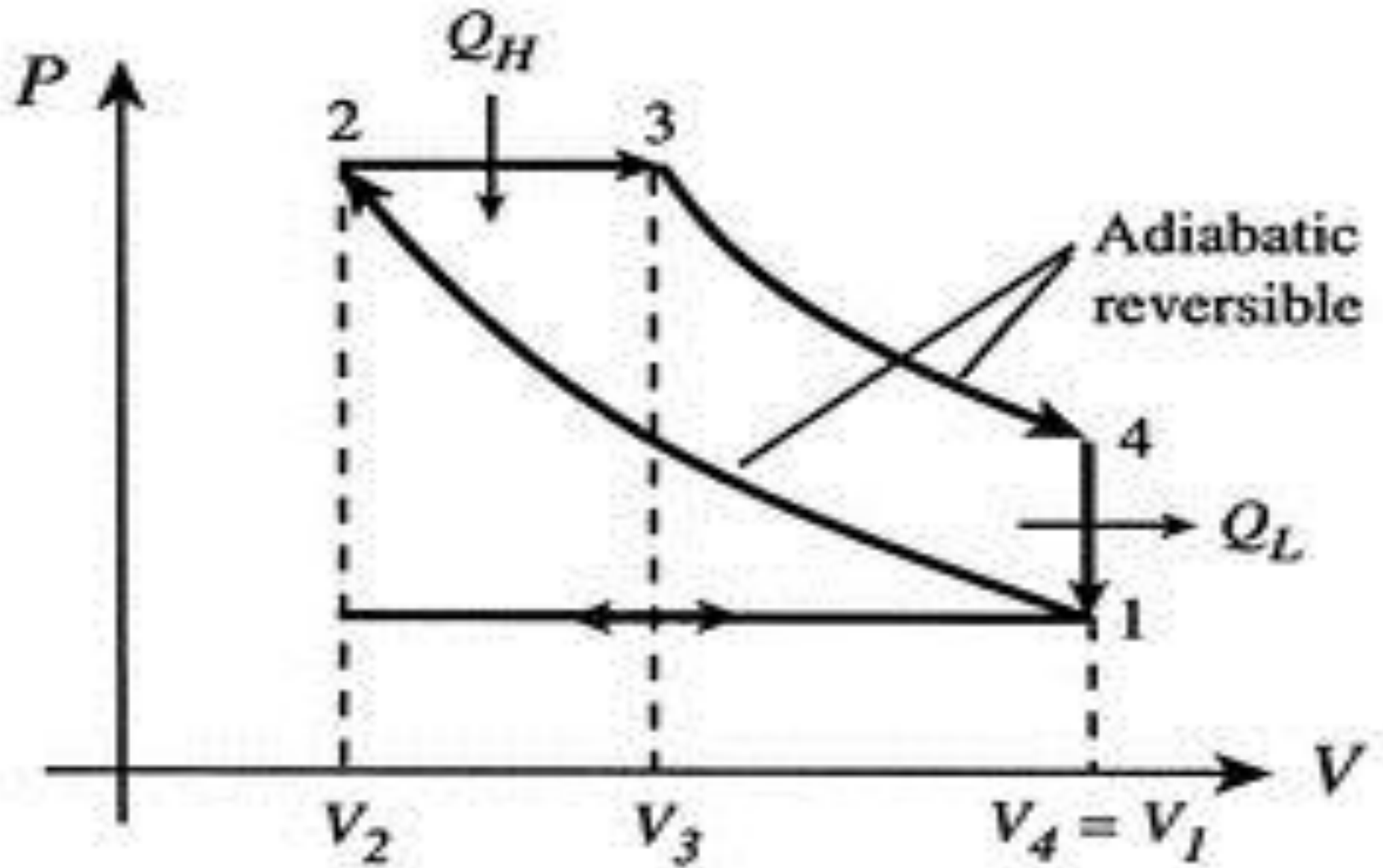

Figure8: Ideal diesel cycle P-V Diagram.

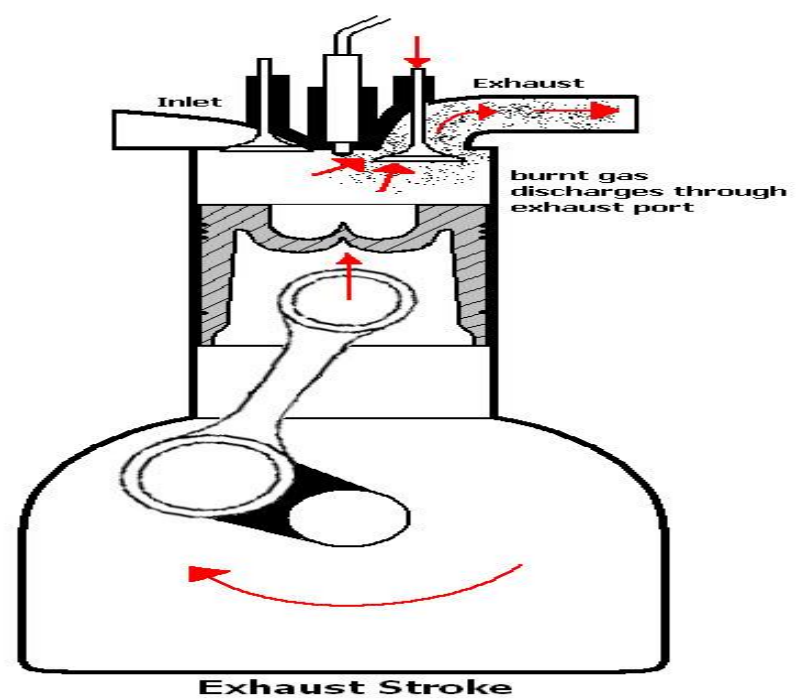
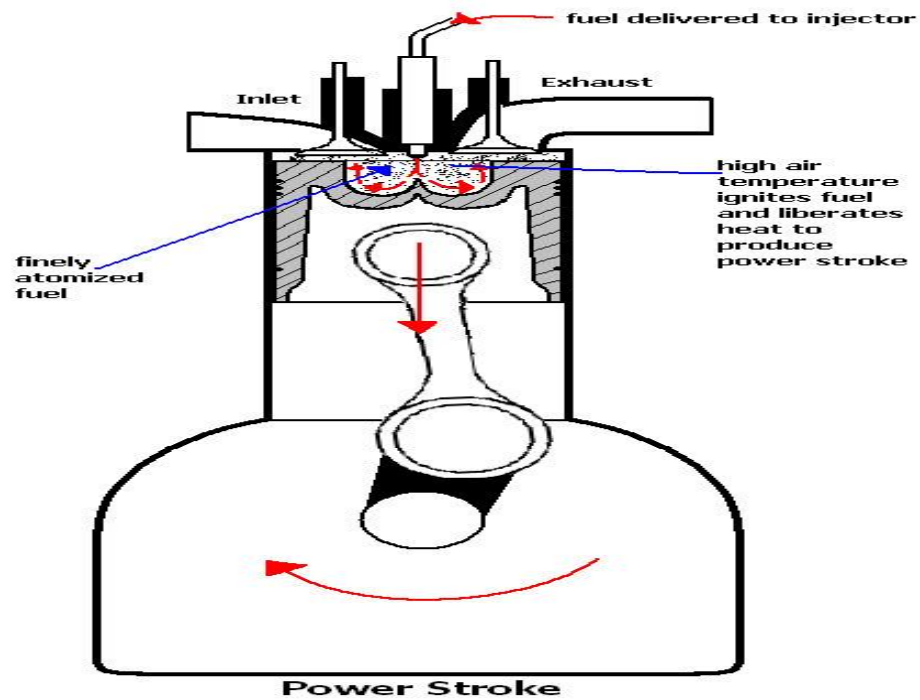
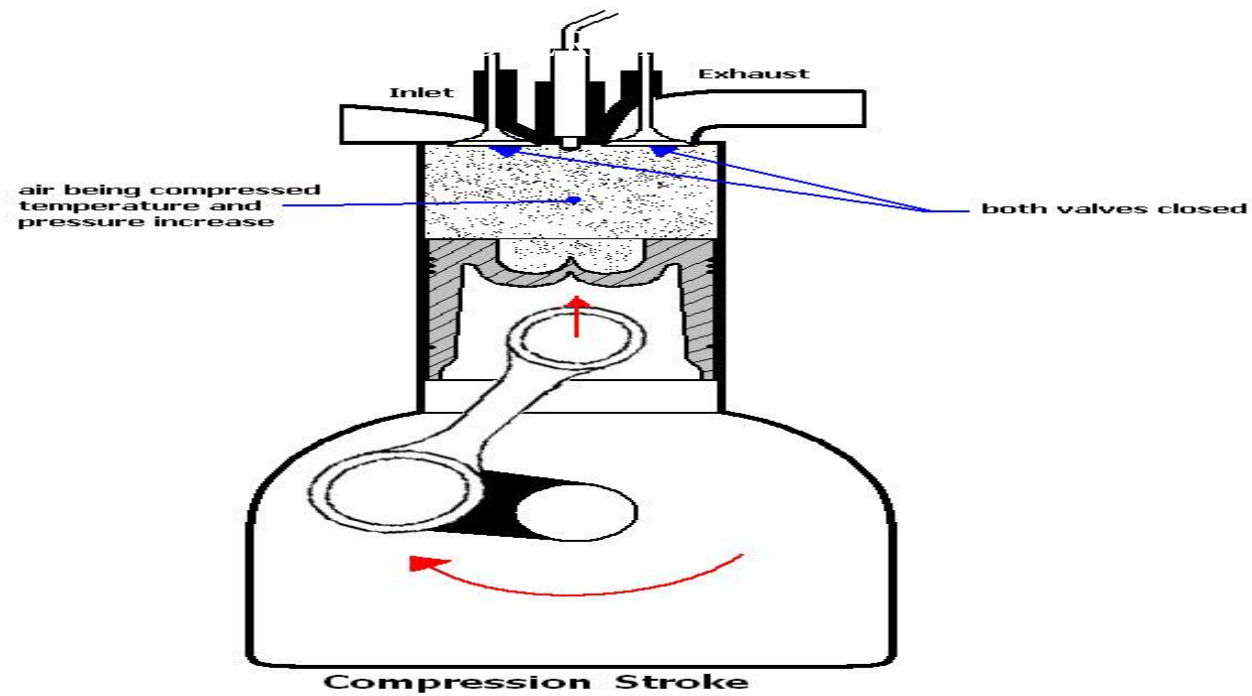
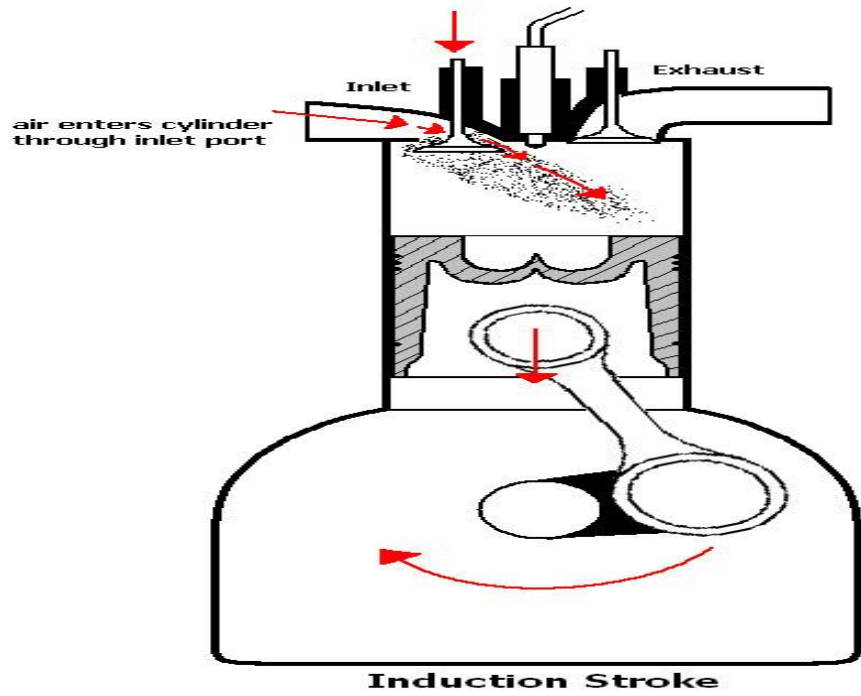

Figure9: Four strokes of ideal Diesel cycle.

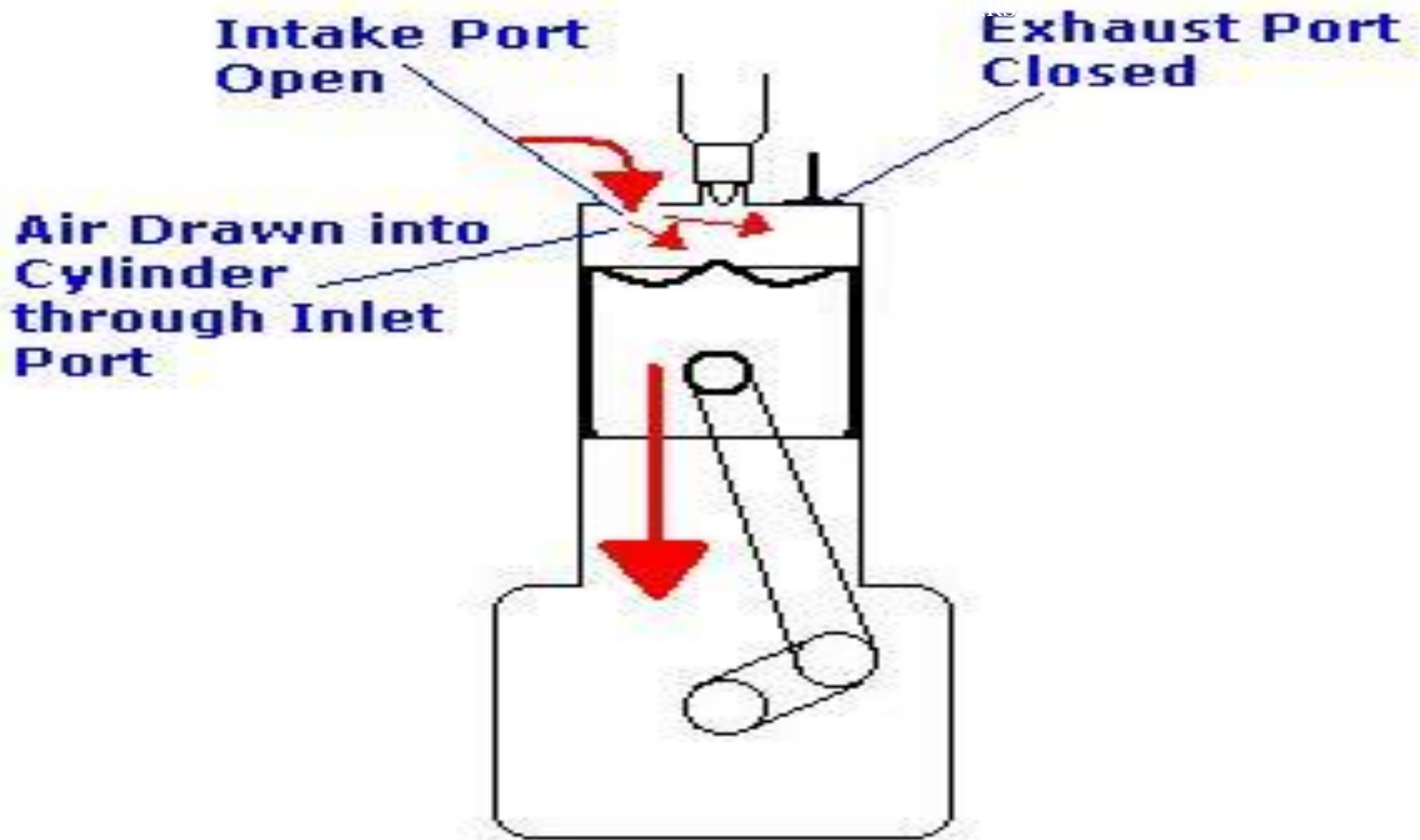

Figure10:Suction stroke

**Inlet Port Closed**

**Exhaust Port Closed**

**Air is compressed**

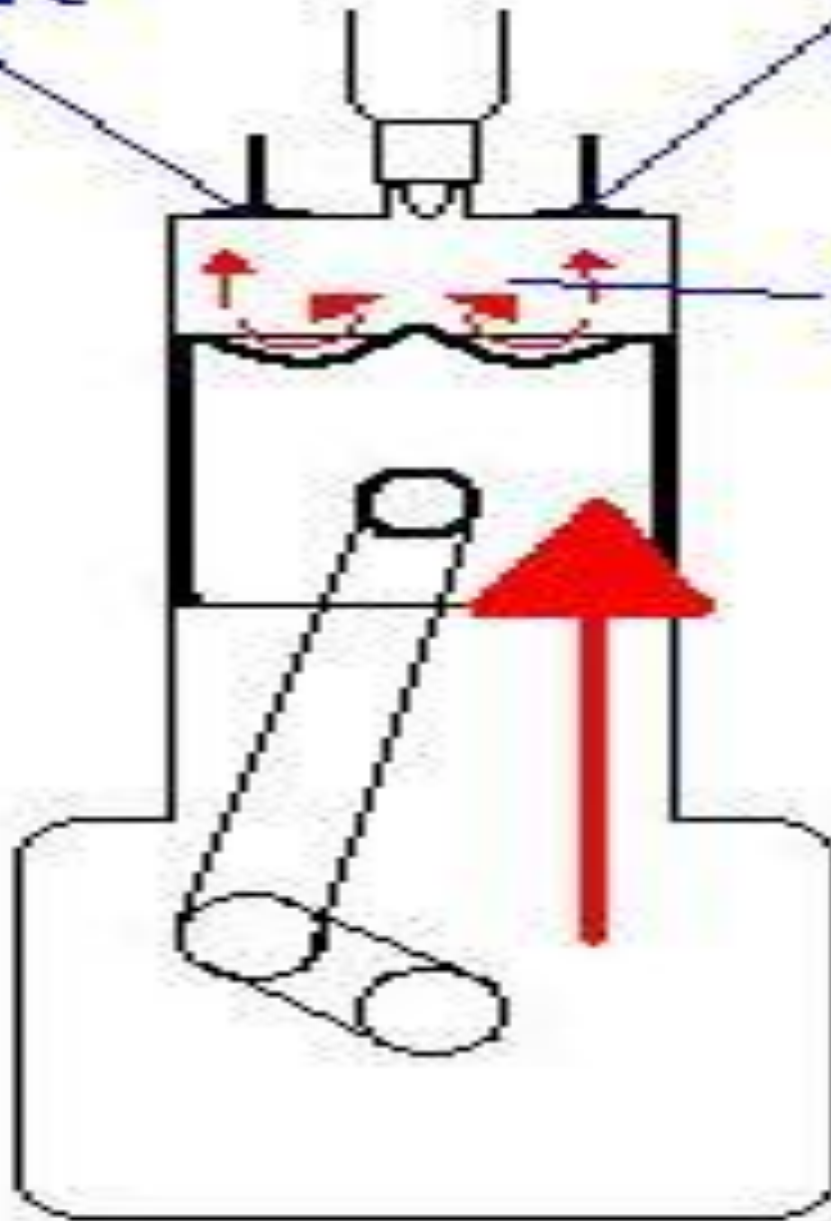

Figure11: Compression stroke

# Four strokes of CI Engine Cycle :

- **Intake/Suction Stroke** : The same as the intake stroke in an SI engine with one major difference : no fuel is added to the incoming air, refer figure 10.
- **Compression Stroke** : The same as in an SI engine except that only air is compressed and compression is to higher pressures and temperature, refer figure 11.
  - Late in the compression stroke fuel is injected directly into the combustion chamber, where it mixes with very hot air.
  - This causes the fuel to evaporate and self ignite, causing combustion to start.
- » **Combustion** is fully developed by TDC and continues at about constant pressure until fuel injection is complete and the piston has started towards BDC, refer figure 12.



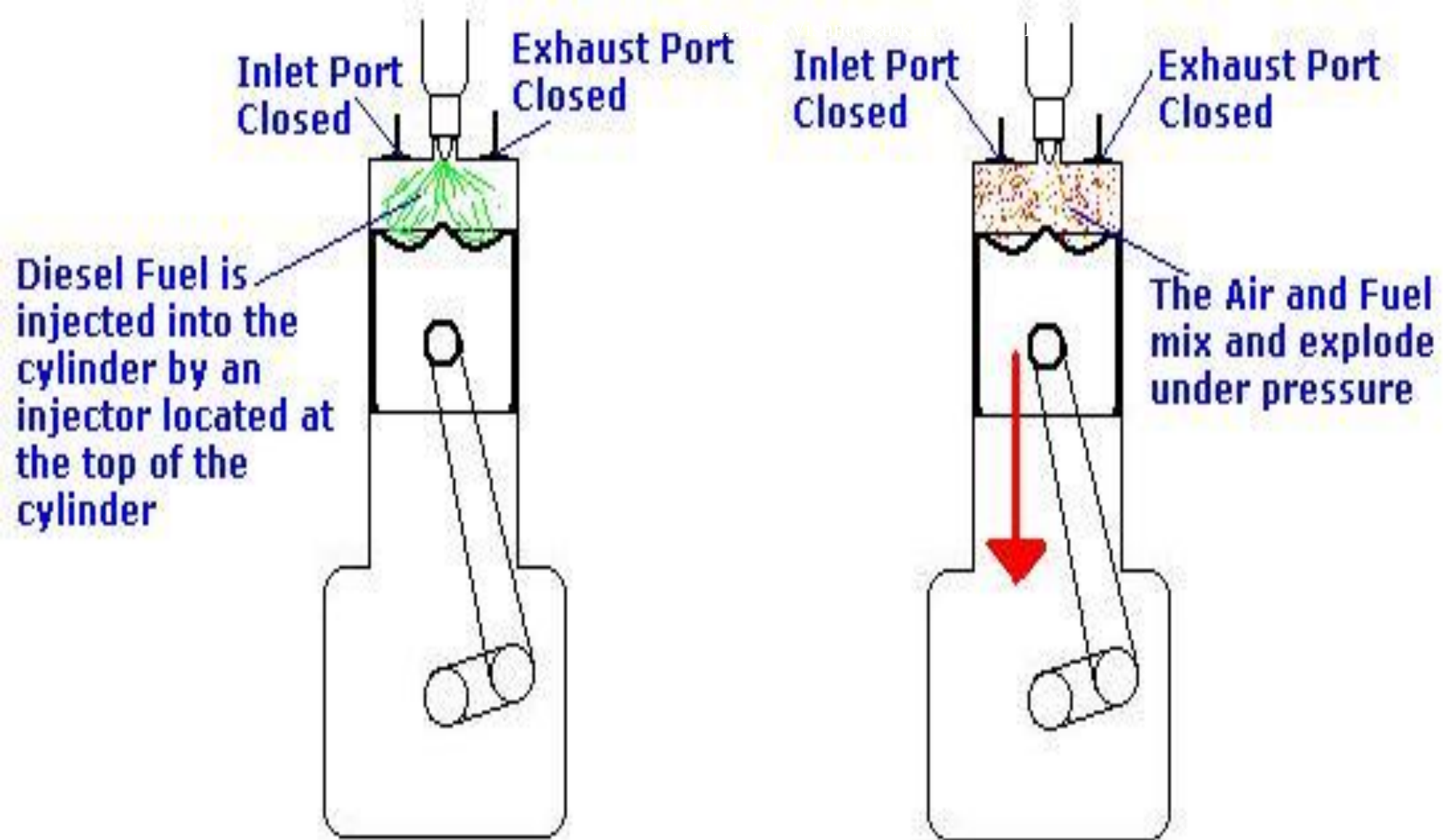

Figure12:Fuel injection and combustion followed by Expansion stroke .

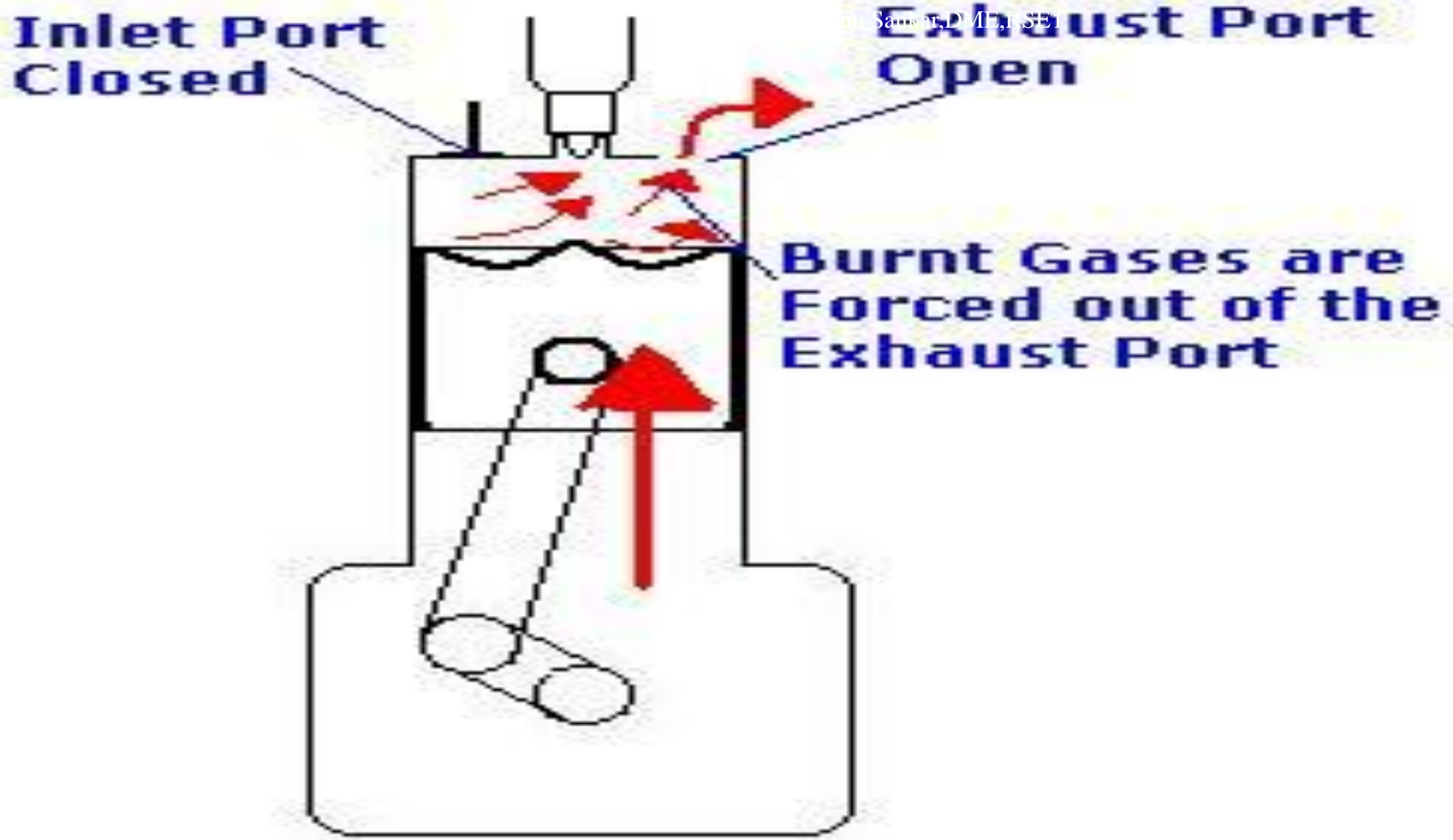

Figure13: Exhaust stroke followed by exhaust blowdown.

- **Expansion/Power stroke** : The power stroke continues as combustion ends and the piston travels towards BDC, refer figure 12.
  - **Exhaust blowdown** same as with an SI engine.
- **Exhaust stroke** : Same as with an SI engine, refer figure 13.



# Concept explanation :

- Animation of internal combustion engine, for the specified 4-stroke engine should be able to show:
  - All four strokes
  - Combustion process
  - Pressure Volume (P-V)diagram.
- Based on the concept explanation on previous slides.

**Describe the concept chosen and clearly illustrate how you want to explain the concept in the animation.**

# Problem statement:

- Animation should show pressure variations during compression and expansion strokes of the engine.
- Graphical representation of pressure variation.
- It helps to know the pressure limits of the engine as well as compression ratio.
- Compression ratio defines the efficiency of the ideal engine cycle.

**Problem Statement :Describe examples/experiments/analogies through which you will explain (use bullets).**

- With the **analogy** of human metabolism one can explain combustion of engine:
  - Human metabolism = Oxidization of food converts chemical energy into Mechanical energy.
    - Food = fuel
    - Oxygen=air
    - Optimum air fuel ratio leads to optimum engine performance = Balanced diet leads to healthy human life.
    - Cooling of engine via water, air or any coolant to maintain its temperature = Human body maintains its temperature by perspiration, sweating.

- User should be able to see the variation of pressure during expansion and compression processes of engine cycle :
  - Compression and Expansion are adiabatic processes defined by relation :
    - $P V^\lambda = \text{constant}$
    - The exponent  $\lambda$  for the compression and expansion processes is 1.4 for conventional fuels.
    - In other strokes, there is no pressure variations.

# Questionnaire :

- Question1 : In which stroke does the engine produce power?
  - Answer : The engine produces power in the expansion stroke of the engine cycle.
- Question2 : What is spark ignition engine and compression ignition engine ?
  - Answer : Spark ignition engine requires external spark to ignite fuel and air mixture for initiating combustion. In Compression ignition engine the air fuel mixture self ignites due to the high temperature caused by high compression.

**A small questionnaire with answers based on the concept.**

- Question3: Define valve overlap and when it occurs in the engine cycle?
  - Answer: The duration of crank angle in which both inlet and exhaust valve remains open is called as valve overlap. It occurs at the end of exhaust stroke when the piston is about to reach TDC and continues for a few degree of crank angle after TDC, refer valve timing chart.

# References:

- <http://www.small-engines.com/4cycleth.html>
- [http://en.wikipedia.org/wiki/Engine\\_displacement](http://en.wikipedia.org/wiki/Engine_displacement)
- [http://en.wikipedia.org/wiki/Stroke\\_\(engine\)](http://en.wikipedia.org/wiki/Stroke_(engine))
- [http://en.wikipedia.org/wiki/Internal\\_combustion\\_engine](http://en.wikipedia.org/wiki/Internal_combustion_engine)
- <http://www.howstuffworks.com/diesel-two-stroke.htm>
- [http://www.mustangmonthly.com/techarticles/97278\\_how\\_engines\\_work/index.html](http://www.mustangmonthly.com/techarticles/97278_how_engines_work/index.html)
- [http://www.kruse-ltc.com/Otto/otto\\_cycle.php](http://www.kruse-ltc.com/Otto/otto_cycle.php)
- [http://www.kruse-ltc.com/Diesel/diesel\\_cycle.php](http://www.kruse-ltc.com/Diesel/diesel_cycle.php)
- <http://www.answers.com/topic/internal-combustion-engine>
- <http://www.britannica.com/EBchecked/topic/162716/diesel-engine>

Links for further reading/references

# References:

- <http://content.answers.com/main/content/img/BritannicaConcise/images/72180.jpg>

- <http://www.howcarswork.co.uk/modules/content/index.php?id=23>  
[http://www.howcarswork.co.uk/modules/articles/index.php?cat\\_id=1](http://www.howcarswork.co.uk/modules/articles/index.php?cat_id=1)

- **Internal Combustion engine fundamentals**

**John B. Heywood**

- **Engineering Fundamentals of the Internal combustion Engine.**

**Willard W. Pulkrabek**



- I am grateful to Prof. U.V. Bhandarkar for his valuable guidance and assessment.